

C. A. COLLORD.  
METAL SHAPING MACHINE.

No. 493,151.

Patented Mar. 7, 1893.

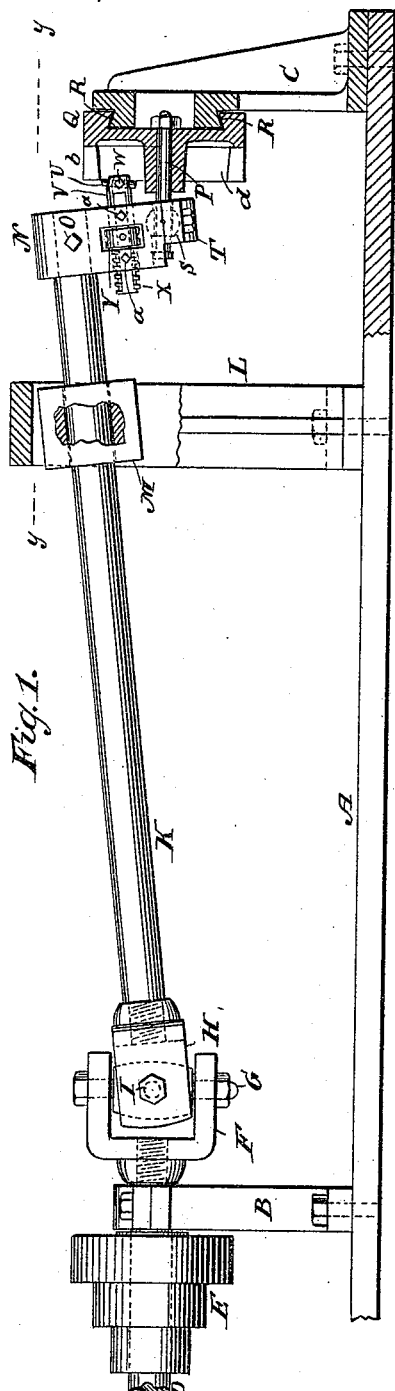

Fig. 1.

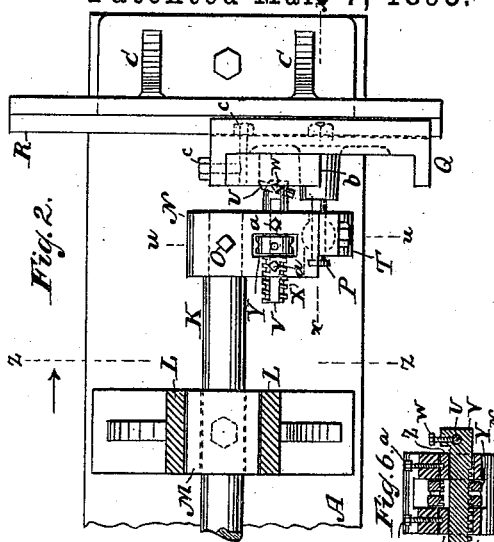

Fig. 2.

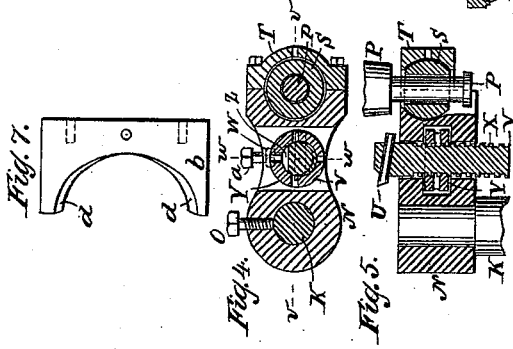

Fig. 7.

Fig. 4.

Fig. 5.

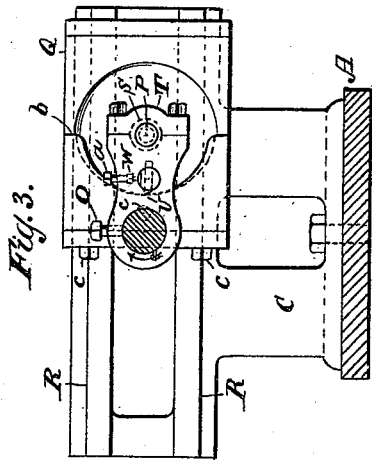

Fig. 3.

WITNESSES:

Edward Wolff.  
William Miller

INVENTOR:

Charles A. Collord  
BY  
Van Santvoord & Hunt  
ATTORNEYS.

C. A. COLLORD.  
METAL SHAPING MACHINE.

No. 493,151.

Patented Mar. 7, 1893.

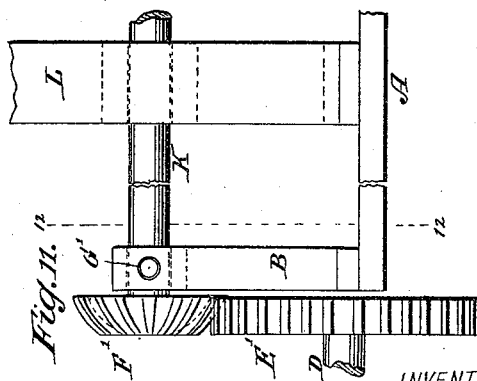
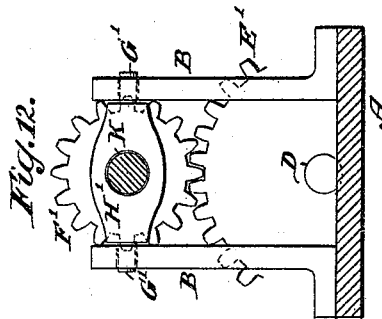
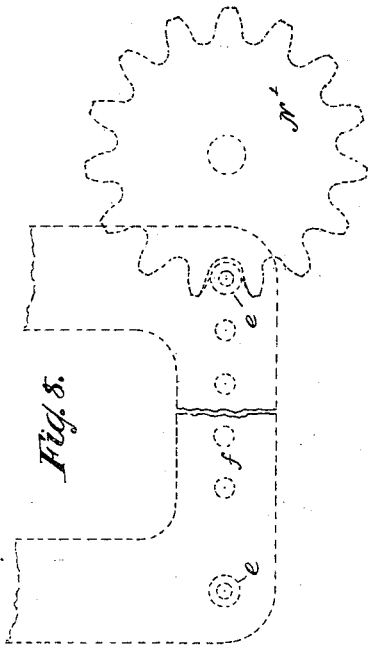
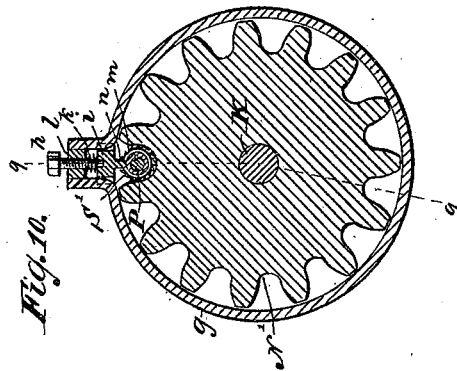
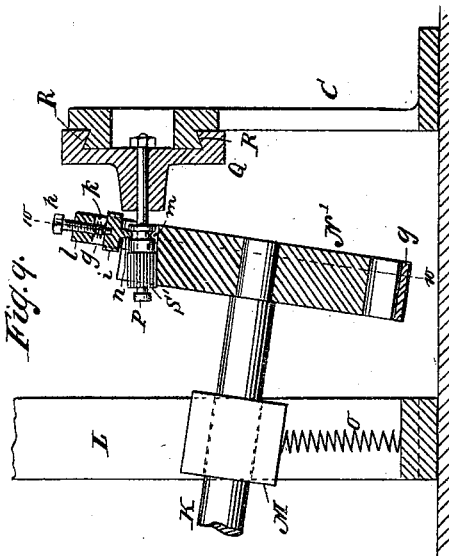

WITNESSES:

*Edward Wolff*  
*William Miller*

INVENTOR:

*Charles A. Collord.*

BY

*Van Santvoord & Hauff*

ATTORNEYS.

# UNITED STATES PATENT OFFICE.

CHARLES A. COLLORD, OF NEW YORK, N. Y.

## METAL-SHAPING MACHINE.

SPECIFICATION forming part of Letters Patent No. 493,151, dated March 7, 1893.

Application filed September 29, 1892. Serial No. 447,254. (No model.)

*To all whom it may concern:*

Be it known that I, CHARLES A. COLLORD, a citizen of the United States, residing at New York, county and State of New York, have invented new and useful Improvements in Metal-Shaping Machines, of which the following is a specification.

This invention relates to an improvement in metal shaping machines and the invention resides in the novel features pointed out in the following specification and claims and illustrated in the annexed drawings, in which

Figure 1, is a side elevation of the machine sectioned along *xx* Fig. 2. Fig. 2, is a plan view of part of Fig. 1 and with parts in a different position than in Fig. 1 and sectioned along *yy* Fig. 1. Fig. 3, is a section along *zz* Fig. 2. Fig. 4, is a section along *uu* Fig. 2. Fig. 5, is a section along *vv* Fig. 4. Fig. 6, is a section along *ww* Fig. 4. Fig. 7, shows an article formed by the machine. Fig. 8, shows an application of an article shaped by use of the movement. Fig. 9, is a side elevation sectioned along 9—9 Fig. 10 showing a modification of the invention. Fig. 10, is a section along 10—10 Fig. 9. Fig. 11, is a side elevation of another modification. Fig. 12, is a section along 12—12 Fig. 11.

In the drawings the letter A indicates a base or supports carrying standards B C. Standard B supports a driving shaft D with its pulley or motor E. The knuckle joint F, G, H, I, connects the shaft K to the driving shaft D, and as the latter rotates the shaft K will rotate therewith but will be left free by the knuckle joint to at the same time swing or oscillate. The guide or ways L guide the swinging or oscillating block M through which the shaft K passes so that the latter is guided in its oscillations.

On the shaft K is supported an arm or carrier N suitably fastened or secured thereto by a bolt or fastening O. The pivot or support P for the free end of arm N is made movable or reciprocating by being mounted on a holder or slide Q which can move or reciprocate on the guide or ways R on standard C. The pivot P carries a suitable bearing S such as a ball bearing which is free to slide or reciprocate a certain distance along the pivot. This

bearing S is suitably seated in the arm N and cap T bolted or fastened to said arm.

A tool or shaper U is secured to a stem V carried by the arm or carrier N. A bolt or fastening W is shown securing the tool U to stem V. Said stem has a screw thread X engaged by a nut Y in a suitable seat or recess in the arm or carrier N. By rotating the nut Y the stem V and tool U will be adjusted or fed as required. The stem V is feathered or adapted to slide or feed in the arm or carrier N without turning therein. By flattening or cutting away part of the stem V and placing into contact with such part a block or blocks Z held in place by screws or fastenings *a* the stem V is prevented from turning but is left free to slide or to be adjusted or fed.

A practical application of my invention is shown in Figs. 1, 2, and 3, where the movement is utilized in shaping a reversing shoe applicable for example in such printing presses as shown in United States patent to Fenner No. 416,587 granted December 3, 1889. Such reversing shoes as is well known are applicable in such printing presses to guide the driving shaft and driving gear of the type bed rack, from one side to the other of said rack as the motion of the type bed is to be changed or reversed. The blank for such a shoe *b* is secured to the holder or slide Q and as the shaft K oscillates and rotates the motion of the shaper or tool U and of the slide Q will cause said tool to shape or cut the operating or reversing face *d* of the shoe *b*, so that said face will act as a proper guide during said reversing motion in printing presses. The tool or shaper U can be fed along in a well known manner like a lathe or planer tool so as to cut or shave off the proper amount of material by degrees. The carrier N if required can obviously be made adjustable along shaft K and if found desirable the shaft K might itself be made adjustable in length by any suitable well known means.

Of course I do not limit the use of my movement to shaping reversing shoes since it can be otherwise utilized. For example the pivot P might be provided with a shaper or tool S' (Fig. 9) in place of the bearing S and in place of the arm or carrier N of Fig. 1 a gear wheel

N' might be mounted on the shaft K and the movement could then be used to shape the space of the gear wheel which engages the end roll or rolls *e* of rack *f* when the gear wheel changes from one side of the rack to the other as illustrated in Fig. 8. This reversing space of wheel N' can be shaped by said tool or shaper S' by keeping the wheel N' in contact with the shaper by a band or holder *g* which clasps the wheel N' and the shaper S'. The swinging and rotating shaft K will carry the reversing space of wheel N' about the shaper at such angles as are required to give the reversing space the proper shape. As the shaper works into or shapes the reversing space the wear or space caused by the tool is taken up by the set screw *h* which is rotated at proper times, so as to keep the block *i* in contact with the tool. This block *i* slides or moves in the band or holder *g* and a spring *k* can be made to press on block *i* to prevent looseness. The spring *k* is shown interposed between the block *i* and the cap *l* on the band *g* which cap *l* is tapped for the screw or bolt *h*. The tool or shaper S' feathers on pivot P so as to be free to slide longitudinally thereon but without turning. As the part of the tool which comes into contact with the band or holder *g* as seen in Fig. 9 does not have to do any cutting or shaping this part of the tool is made plain or smooth and by providing said plain part of the tool with a groove *m* engaged by a lug *n* on the block *i*, said tool will be kept in proper position on the pivot P to accurately shape the required space on gear wheel N'. The weight or pressure of shaft K can be eased by a counterweight or spring of sufficient strength suitably applied.

In place of a knuckle joint F G H I (Fig. 1) any equivalent device can of course be used. For example in Fig. 11 the driving shaft D has a gear wheel E' engaging gear F' and the pivots or bearings G' swing in standards B and have an arm or box H' in which shaft K rotates. The pivots or bearings G' allow shaft K to swing or oscillate and by properly shaping or rounding gear F' the latter will keep in mesh with wheel E' during the swing or oscillations of shaft K.

What I claim as new, and desire to secure by Letters Patent, is—

1. The combination with an oscillating and rotating shaft, of an arm or carrier supported by the shaft and a movable pivot or support for the arm substantially as described. 55
2. The combination with an oscillating and rotating shaft of an arm or carrier supported by the shaft a pivot or support for the arm and a movable holder or slide for the pivot said arm or carrier being adapted to carry a shaper or tool and said slide being adapted to carry a blank for the action of the tool substantially as described. 60
3. The combination with an oscillating and rotating shaft of an arm or carrier supported by the shaft, a shaper or tool adjustably mounted on the carrier and a movable pivot or support for the carrier substantially as described. 65
4. The combination with an oscillating and rotating shaft adapted to support an article to be shaped of a movable pivotal tool or shaper made to engage said article substantially as described. 70
5. The combination with an oscillating and rotating shaft adapted to support an article to be shaped of a movable pivot or support for the article, part of said pivot or support being made in form of a tool or shaper substantially as described. 75
6. The combination with an oscillating and rotating shaft adapted to support an article to be shaped, of a pivot or support being made in form of a tool or shaper and a movable bearing in which the tool is feathered substantially as described. 80
7. The combination with an oscillating and rotating shaft of a counterweight or balance for the shaft an arm or carrier supported by the shaft and a movable pivot or support for the arm substantially as described. 85

In testimony whereof I have hereunto set my hand in the presence of two subscribing witnesses.

CHARLES A. COLLORD.

Witnesses:

WM. C. HAUFF,  
E. F. KASTENHUBER.